

FLAGHOUSE®

#35529

FLAGHOUSE INDOOR SWING FRAME

ASSEMBLY INSTRUCTIONS & PARTS LIST

FOR BEST RESULTS, PLEASE READ THE FOLLOWING BEFORE ASSEMBLY AND USE.

PARTS LIST

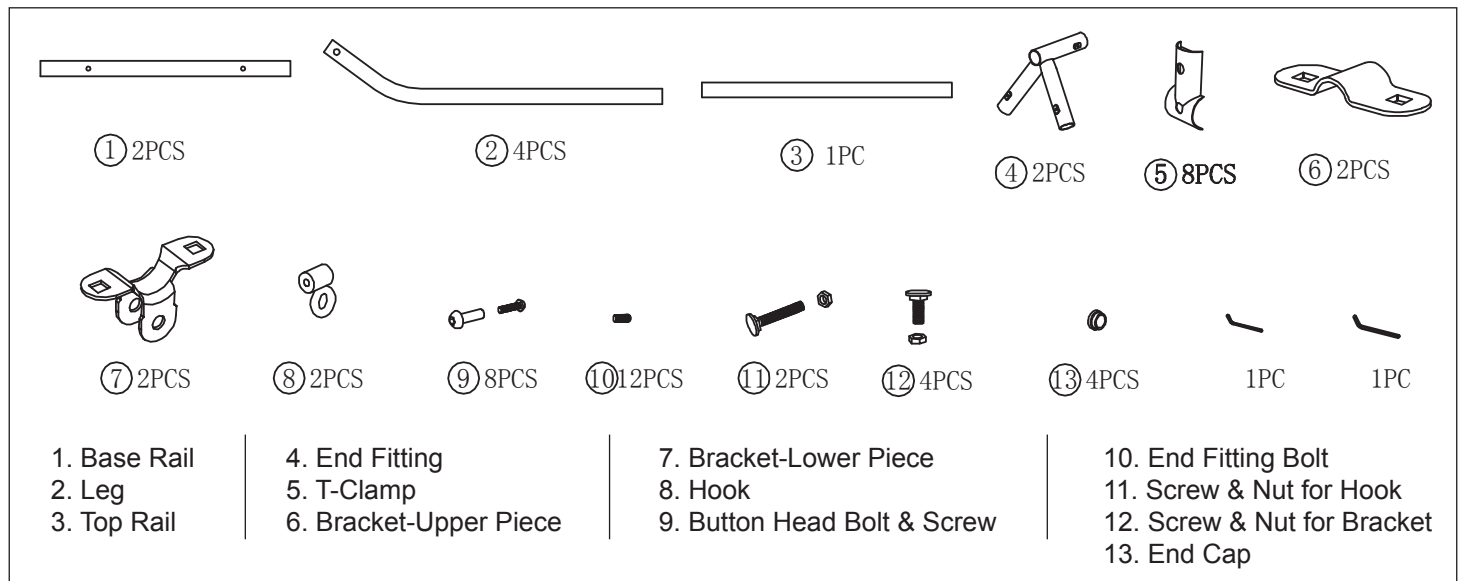

IMPORTANT

Please retain this instruction sheet in your files. It contains replacement parts information. All equipment should be installed in accordance with these instructions.

It is important to use and maintain all public playground equipment properly. FLAGHOUSE INDOOR SWING FRAME, which is improperly maintained, can cause serious injury. Periodic inspections, maintenance, repair and/or replacement of damaged parts is necessary for safe operation of equipment and safety of users.

GENERAL USE/FALL ZONE & FOOTING RECOMMENDATIONS:

SINGLE AXIS SWINGS:

The Use/Fall Zone should extend to the front & rear, a minimum distance of twice the height of the Top Rail(#3) above the resilient surfacing material. The Use/Fall Zone to the sides should follow the general recommendation of six feet minimum. The six foot zone may overlap that of an adjacent swing structure.

MULTI AXIS SWINGS:

The Use/Fall Zone should extend in all directions the length of the swing plus six feet. The six foot minimum fall zone from the supporting structure also applies, and may overlap the size foot zone of an adjacent swing structure.

GENERAL MAINTENANCE INSTRUCTIONS:

Check MONTHLY for loose bolts, damaged, or broken parts. Tighten and/or replace immediately. On swings and any equipment that uses Hooks (part#8) and/or Swing Hangers (part#6 & #7) check the bearing surfaces for wear. Replace any parts that show a reduction of 25% from the original size.

SPECIFIC ASSEMBLY INSTRUCTIONS:

1. Assembly swing frame on ground attach top rail and legs to end fitting (part#4).
2. Attach frame to base rails with T-Clamps(part#5)
3. Stand upright. Plumb and level entire unit. Tighten all nuts & bolts. Attach swing hangers (part#6 & #7).
4. Top Rail bolting is required. The Top Rail (part#3) must be bolted into each of the End Fittings (part#4).

KEEP THIS INSTRUCTION MANUAL IN CASE YOU HAVE TO CONTACT MANUFACTURER FOR REPLACEMENT PARTS.

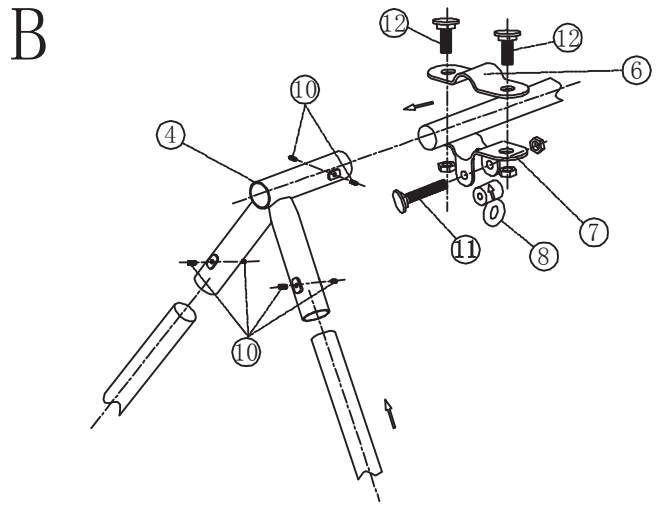
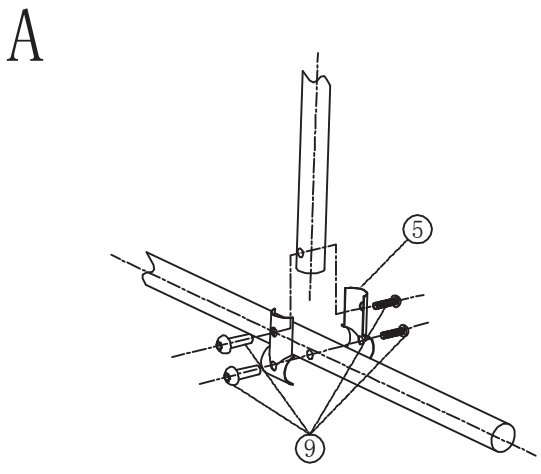
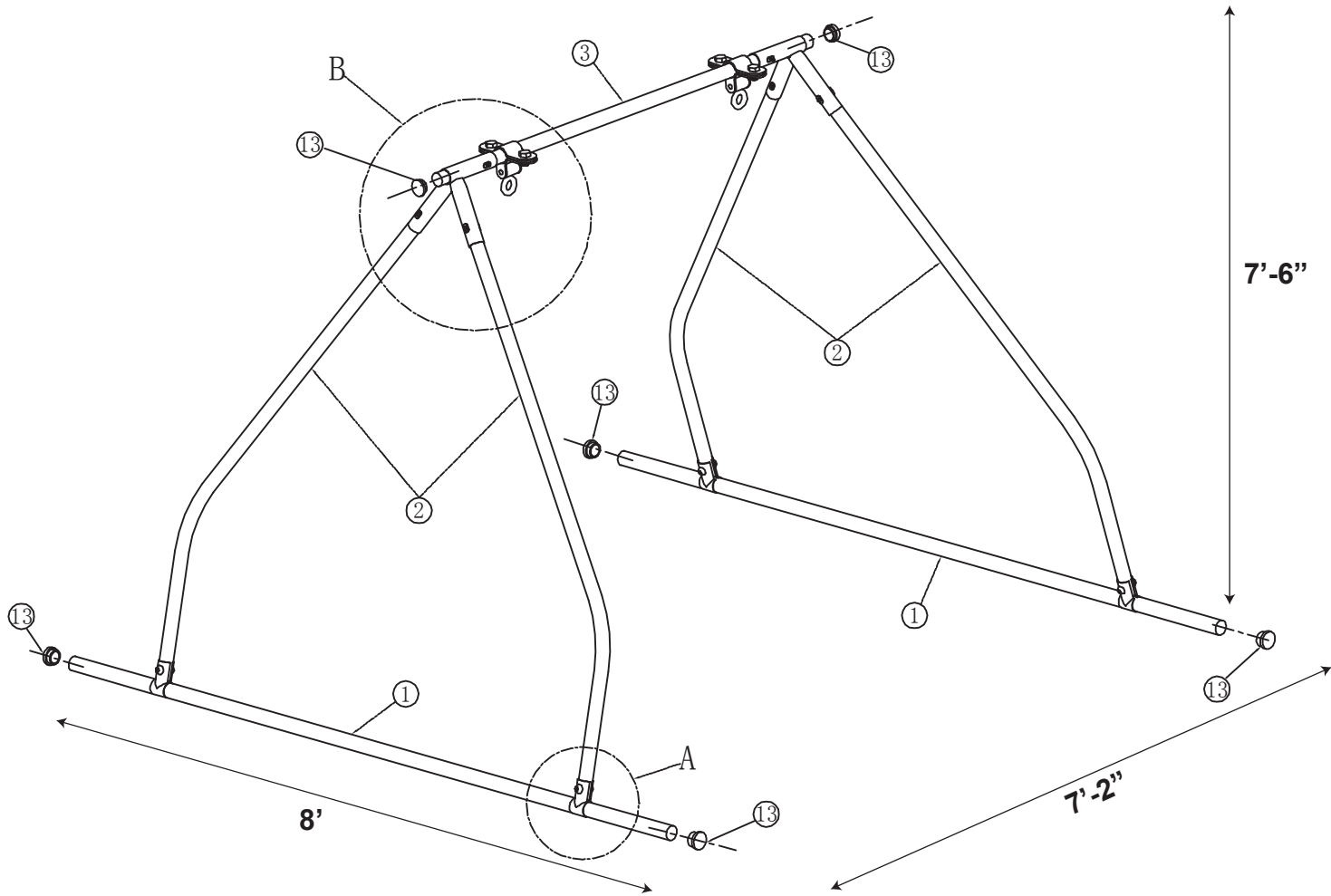

DISCLAIMER: To ensure safety, this product must be assembled, installed, and used in strict conformity with the instructions and specifications provided. All warranties of any kind, including, but not limited to, warranties of merchantability or fitness for a particular purpose, are expressly disclaimed and no warranty of any kind is implied or expressly made. FlagHouse shall not be liable for any direct, indirect, special, incidental, or consequential damages arising or resulting from the sale, use, replacement, or repair of this product.

For more information on this item or our entire line of storage products, please contact the appropriate office below:

In the U.S.

FlagHouse, 601 FlagHouse Drive,
 Hasbrouck Hts., New Jersey 07604-3116
 Phone 800.793.7900 • Fax 800.793.7922

International Customers

FlagHouse, 601 FlagHouse Drive,
 Hasbrouck Hts., New Jersey 07604-3116 USA
 Phone 201.288.7600 • Fax 201.288.7887
 8AM-6PM Eastern Time

In Canada

FlagHouse Canada, 235 Yorkland Blvd.,
 Suite 105, North York, Ontario M2J 4Y8
 Phone 800.265.6900 • Fax 800.265.6922

Made in China